

INTEGRATED CONNECTOR MODULES

0826-1X1T-23-F Gigabit Ethernet Single Port MagJack® with LEDs



LED1 POLARITY			LED2 POLARITY		
PIN 13	PIN 14	COLOR	PIN 15	PIN 16	COLOR
-	+	YELLOW	+	-	ORANGE
/	/	/	-	+	GREEN

ELECTRICAL CHARACTERISTICS @ 25°C

URNS RATIO

TP1	1CT : 1CT ±2%
TP2	1CT : 1CT ±2%
TP3	1CT : 1CT ±2%
TP4	1CT : 1CT ±2%

CL @ 100kHz/100mVRMS 8mA DC BIAS

350µH MIN.

INS. LOSS

0.1MHz TO 1MHz	-1.1 dB MAX
1MHz TO 65MHz	-0.5 dB MAX
65MHz TO 100MHz	-0.8 dB MAX
100MHz TO 125MHz	-1.2 dB MAX

RET. LOSS (MIN)

0.5MHz-40MHz	-18 dB
40MHz-100MHz	-12+20LOG(f/80MHz) dB

CM TO CM REJ

100kHz - 100MHz -30 dB MIN

CM TO DM REJ

100kHz - 100MHz -35 dB MIN

HIPOT (Isolation Voltage):

1500 Vrms

LED 1

V _F (FORWARD VOLTAGE)	IF=20mA	YELLOW	2.1V TYP.
λ _D (DOMINANT WAVELENGTH)	IF=20mA	YELLOW	590nm TYP.

LED 2

V _F (FORWARD VOLTAGE)	IF=20mA	GREEN	2.2V TYP.
		ORANGE	2.0V TYP.
λ _D (DOMINANT WAVELENGTH)	IF=20mA	GREEN	565nm TYP.
		ORANGE	610nm TYP.

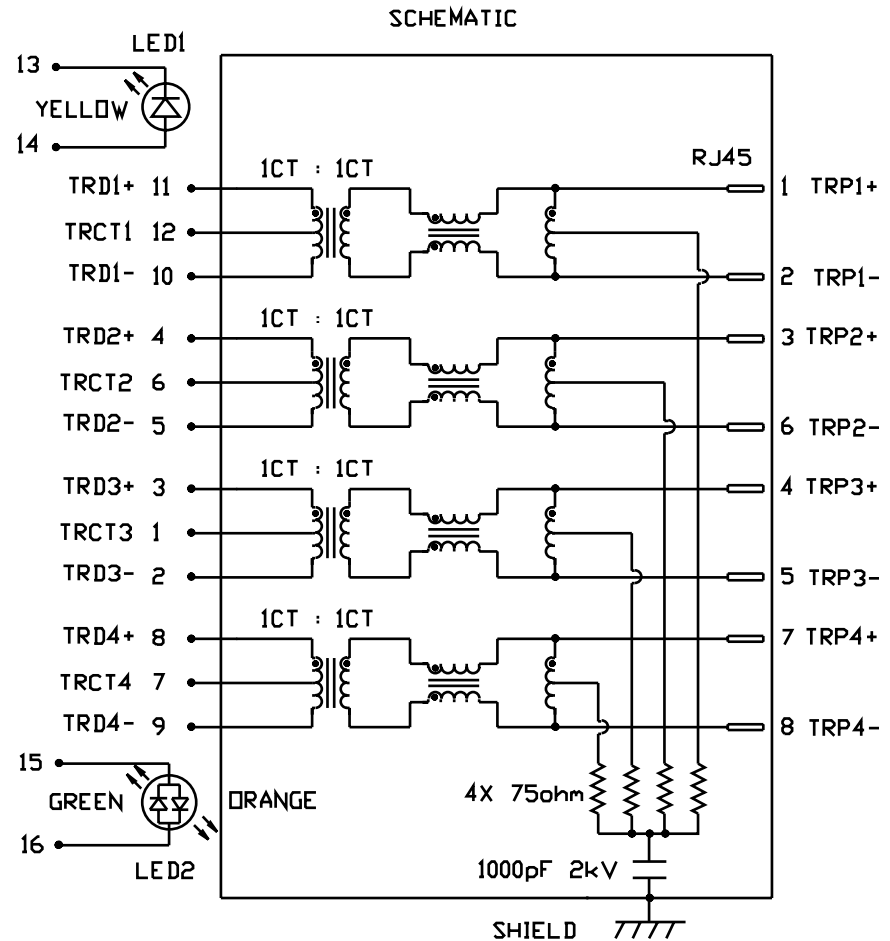

INTEGRATED CONNECTOR MODULES

0826-1X1T-23-F Gigabit Ethernet Single Port MagJack® with LEDs

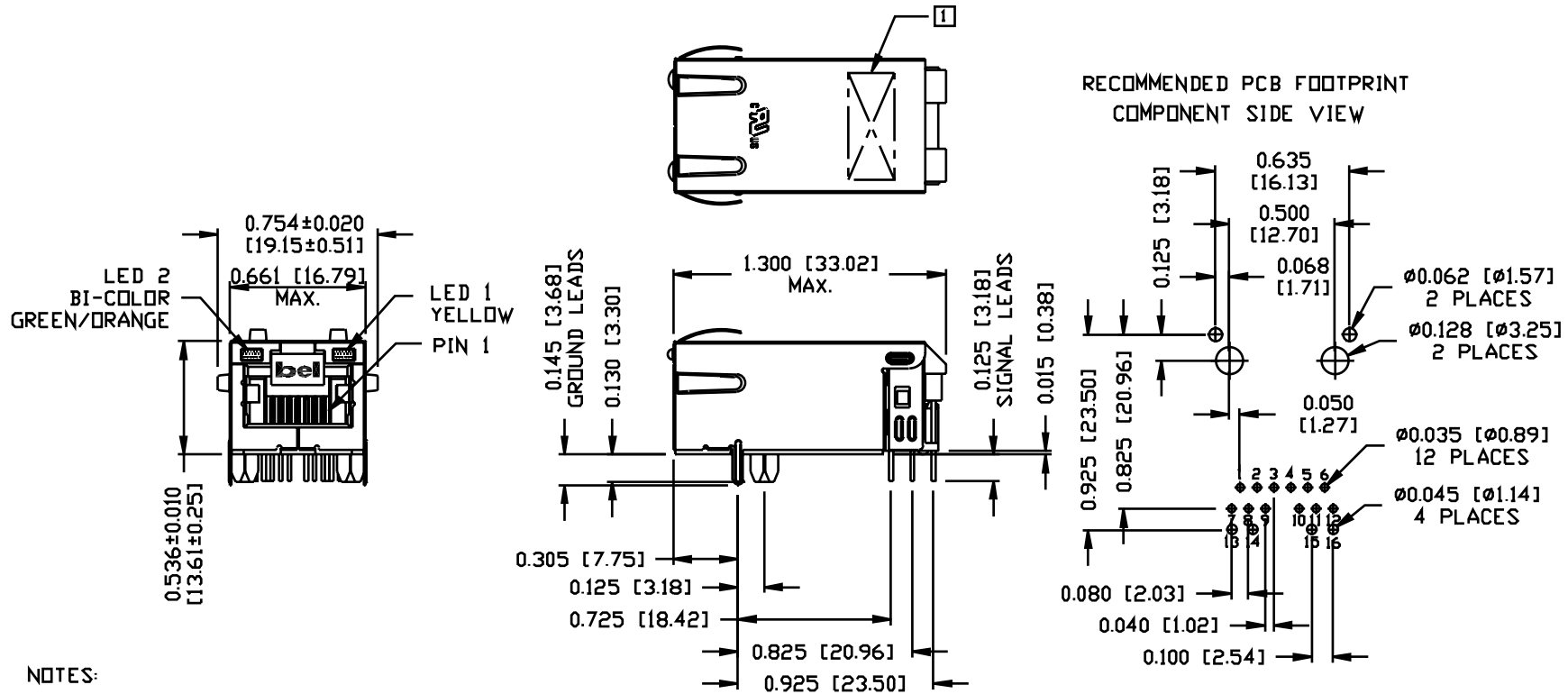

NOTES:

- PLASTIC HOUSING: THERMOPLASTIC PA 4/6
FLAMMABILITY RATING UL 94V-0
- CONTACTS: 50 MICRO-INCH HARD GOLD PLATING
- OUTPUT PINS: TIN-COATED COPPER WIRE, DIA 0.018 INCH.
- METAL SHIELD: NICKEL OR TIN PLATED ON COPPER ALLOY.
(NICKEL GROUND LEADS ARE SOLDER DIPPED)

☐ MARK PART WITH MFG LOGO, MFG NAME, PART NUMBER, AND DATE CODE.

UL RECOGNIZED - FILE #E196366 AND E169987.

2. RoHS COMPLIANCE, PER EU DIRECTIVE 2002/95/EC.

INTEGRATED CONNECTOR MODULES

0826-1X1T-23-F Gigabit Ethernet Single Port MagJack® with LEDs



SUGGESTED PANEL OPENING

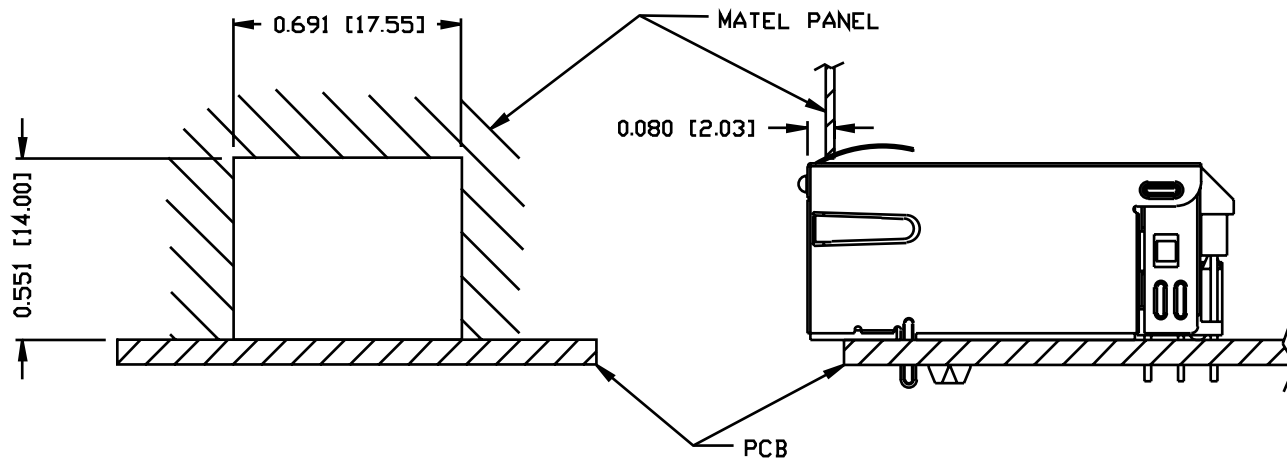

NOTE:

THE DISTANCE OF PANEL INSIDE SURFACE RELATIVE TO FRONT SURFACE OF PART IS ONLY A SUGGESTION. IN CASE THIS DISTANCE IS DIFFERENT, THE REQUIRED PANEL OPENING DIMENSIONS CHANGE ACCORDINGLY.

PACKING INFORMATION

PACKING TRAY : 0200-9999-F6 (TOP)
0200-9999-F7 (BOTTOM)

PACKING QUANTITY : 40 PCS FINISHED GOODS PER TRAY
10 TRAYS (400 PCS FINISHED GOODS) PER CARTON BOX

NOTE : CARDBOARDS ARE PLACED BETWEEN LAYERS OF PACKING TRAY INSIDE CARTON BOX
(INCLUDE THE UPPERMOST AND LOWERMOST TRAY)